



Welcome to the Virtual CICS user group newsletter. The Virtual CICS user group at www.fundi.com/virtualcics is an independently-operated vendor-neutral site run by and for the CICS user community.

Virtual CICS user group presentation

The latest webinar from the Virtual CICS user group was entitled, "CICS Transaction Gateway V8.1", and was presented by Andrew Smithson, CICS Transaction Gateway Development Software Engineer with IBM Hursley.

Andrew is the lead developer for the CICS Transaction Gateway team. He has worked as part of the CICS Transaction Gateway team for the last eight years, specializing in application development using Java, JEE, C and .NET, security and SSL.

Andrew divided his presentation into three parts, firstly discussing what CICS TG is, then moving on to what's new in CICS TG V8.1, and finishing by giving the

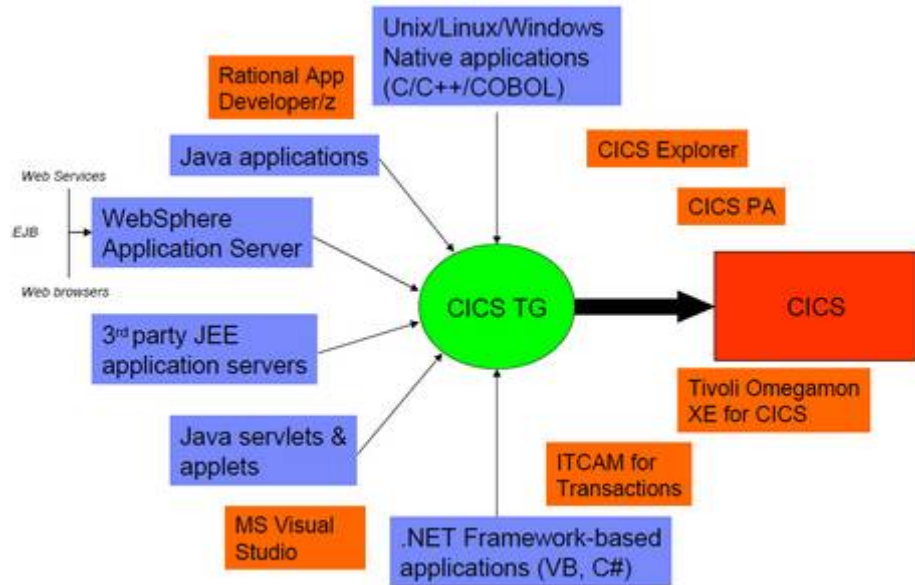

Figure 1: What CICS TG is

user group some reference resources.

Andrew informed us that CICS Transaction Gateway is:

- Interconnected – optimized for WebSphere Application Server but open to all. CICS TG delivers connectivity for other JEE applications servers, in addition to Unix/Linux and

Contents:

Virtual CICS user group presentation	1
Meeting dates	4
Recent CICS articles	4
CICS news	4
About the Virtual CICS user group	4

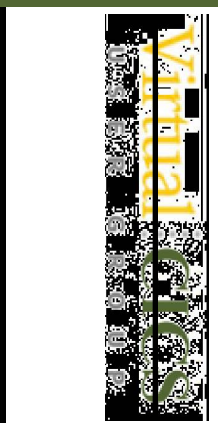
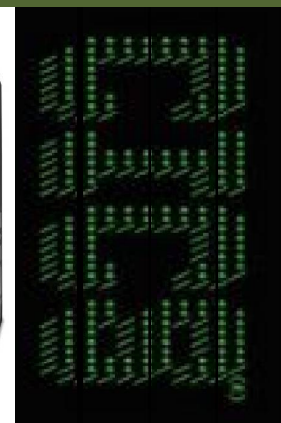
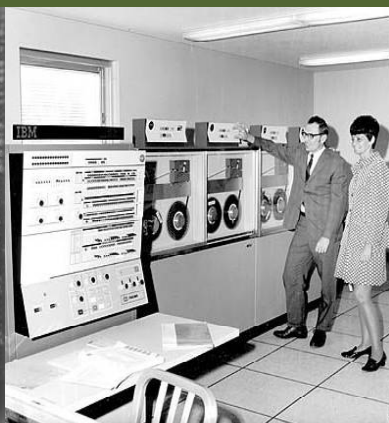
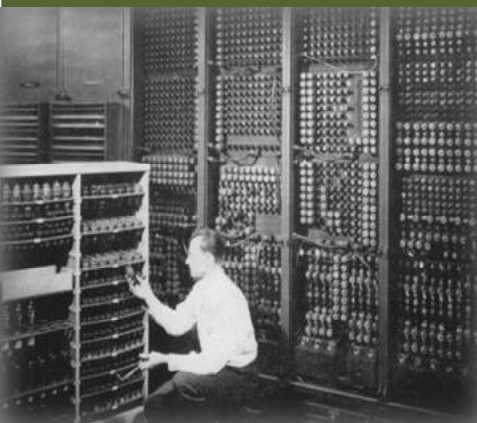

Microsoft .NET environments

- Instrumented – systems monitoring delivers improved visibility of workload for greater management of resources, including interoperability with Tivoli Omegamon XE and CICS PA, along with visibility in the CICS Explorer
- Intelligent – high availability delivers scalability and fail-over support across the IBM System z Parallel Sysplex.

Figure 1 illustrates all the connections that can be made with CICS TG. It acts as the primary inbound connector to CICS from multiple platforms providing multi-user and multi-application connectivity to CICS from local server applications and remote clients. It's non-invasive to existing CICS resources after connection definitions, and uses CICS connectivity protocols such as IPIC (all platforms), EXCI (system Z), and SNA or TCP/IP (multiplatforms).

New Gateway daemon configuration options on z/OS with Dynamic Server Selection provide:

- New configuration file sections DSSGroups, DSSPolicies
- A DSSGroup defines a lists

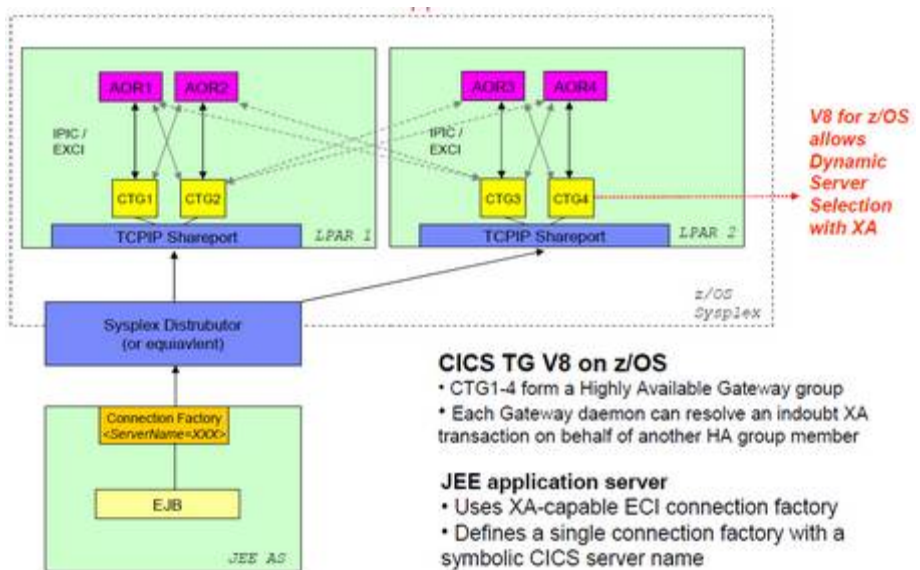

Figure 2: HA/XA support with DSS

of CICS servers, and a selection algorithm. The selection algorithm can be RoundRobin or FailOver

- A DSSPolicy maps application requests to a DSSGroup.
- Logical Servers are now deprecated; migrate to the new syntax.

CICS TG for z/OS V8 with HA/XA support with DSS is shown in Figure 2.

User exit based Dynamic Server Selection now added to multiplatforms:

- New Dynamic Server Selection capability for Multiplatforms is added in V8.1 through inclusion of the CICS Request Exit.
- Provides DSS for applications using remote mode ECI and ESI:

- Java base classes, JCA (ECI), ECI Version 2, CICS TG .NET API
- CICS connection using protocols SNA, ECI/TCPIP, IPIC
- Supports channel and container ECI requests with IPIC
- Allows dynamic interaction through the command line interface.

- Strategic replacement for older Client daemon C-language user exits.
- Compatible with Support Pac CA1T, providing rich DSS options.

Note: no XA in remote mode, or IPIC SSL for MP remote mode.

Cloud integration with IBM Workload Deployer V3:

- IBM Workload Deployer now includes support for CICS connectivity
- JEE Enterprise Applications requiring access to CICS are composed visually, using MQ, WebServices, or CICS TG for connectivity

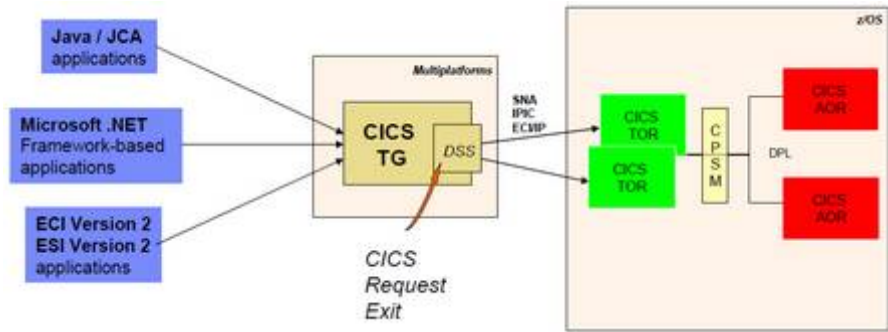

Figure 3: CICS Request Exit configuration

- Enterprise Applications deployed into the cloud benefit from elastic scalability, maximizing efficient use of resources.

Run time improvements for Microsoft .NET Framework include:

- The CICS TG .NET API is now fully interoperable with 32- and 64-bit applications, and runs purely in “managed mode”
- The run time dependency upon the ECI Version 2 run time library (ctgclient.dll) has been removed

Improved CICS TG API for Microsoft .NET Framework includes:

- ECI requests now formally support CICS channels and containers. Relief from the 32KB COMMREA limit
- ESI requests now available for Password Expiry Management
- ECI and ESI requests include support for password phrases, for use with CICS TS for z/OS

V4.2.

Usability improvements for z/OS configuration include:

- The Gateway daemon on z/OS can now read configuration from a partition dataset member, or as a sequential dataset, as well as Unix System Services (zFS / HFS)
- Allows JCL, environment variables, and configuration data to be stored within a single PDS if desired – encapsulating all CICS TG for z/OS configuration data and related JOBS in a single location
- Easier to review, manage, apply version control, backup or duplicate Gateway daemon configurations.

The enhanced CICS TG plug-in for CICS Explorer provides:

- Updated to include latest statistics for V8.1.
- Improved connection administration:

- Import/export of CICS TG connection definitions.

- User defined Gateway groups:
 - Alternative to automatic grouping my APPLID qualifier
 - Useful for providing a common view to all CICS Explorer users.
- Sortable columns in Gateways and Connections views
- Enhanced Gateway daemon and CICS connection tests:
 - Addresses potential issues related to DNS resolution issues, especially with multiple TCPIP stacks on z/OS.

Andrew Smithson went on to provide a range of CICS TG resources.

A copy of Andrew’s presentation is available for download from the Virtual CICS user group Web site at

www.fundi.com/virtualcics/presentations/CICSTG81Jan12.pdf.

You can see and hear the whole user group meeting by downloading the WMV file from www.fundi.com/virtualcics/presentations/2012-01-17meeting.wmv.

Meeting dates

The following meeting dates have been arranged for the Virtual CICS user group:

- Date: 6 March 2012
- Date: 8 May 2012
- Date: 10 July 2012
- Date: 11 September 2012
- Date: 13 November 2012.

We will be using Citrix GoToMeeting for the user group meetings.

All meetings start at 10:30 Central Time (4:30 GMT in the winter and 3:30 GMT during daylight saving time).

Recordings of meetings are available for download from our Web site for people who were unable to attend the meeting.

Recent CICS articles

IBM CICS System Management: New CICSplex SM WLM Features in Version 4.2 by Mayur Raja and Dave

Williams in *zJournal* (December 2011/January 2012). You can find the article at www.mainframezone.com/it-management/ibm-cics-system-management-new-cicsplex-sm-wlm-features-in-version-4.2

Common COBOL/VSE Applications for Use in CICS and Batch Environments by Garry Hasler in *zJournal* (December 2011/January 2012). You can find the article at www.mainframezone.com/it-management/common-cobol-vse-applications-for-use-in-cics-and-batch-environments

CICS Transaction Server for z/OS V4.2: Scalability Enhancements by John Tilling in *zJournal* (December 2011/January 2012). You can find the article at www.mainframezone.com/it-management/cics-transaction-server-for-z-os-v4.2-scalability-enhancements

CICS Transaction Server for z/OS V4.2 and Threadsafe Database Control for IMS by Russ Evans in *zJournal* (December 2011/January 2012). You can find the article at www.mainframezone.com/it-management/cics-transaction-server-for-z-os-v4.2-and-threadsafe-database-control-for-i

CICS news

Compuware has announced Abend-AID Version 12.2. This fault resolution tool includes new features such as a COBOL PERFORM trace, consolidated displays of IMS and DB2 data to speed access to crucial information, and easier access to Abend-AID reports. More information can be found at www.compuware.com/about/release/643555/compuwares-latest-innovations-enable-enterprises-to-successfully-navigate-the-new-normal-of-mainframe.

About the Virtual CICS user group

The Virtual CICS user group was established as a way for individuals using IBM's CICS TS systems to exchange information, learn new techniques, and advance their skills with the product.

The Web site at www.fundi.com/virtualcics provides a central point for coordinating periodic meetings (which contain technically-oriented topics presented in a webinar format), and provides articles, discussions, links, and other resources of interest to IBM CICS practitioners. Anyone with an interest in CICS is welcome to join the Virtual CICS user group and share in the knowledge exchange.

To share ideas, and for further information, contact trevor@itech-ed.com.

The Virtual CICS user group is free to its members.